

# WIRE CUTTER LINDOVA TA14

SEE OUR ENTIRE PRODUCT RANGE AT: [WWW.LINDOVA.SE](http://WWW.LINDOVA.SE)



## Air hydraulic cutting tool for steel wire up to $\varnothing 8$ mm

Lindova TA14 is an air hydraulic cutting tool. The design allows the user to work using rapid strokes and considerable force.

TA14 can usefully be utilised on harder materials, including spring steel, available for both fixed workstations and mobile use.

The tool is both light weight and well-balanced to minimize the strain on the user. The air hydraulics also mean that the tool runs silently and is completely vibration-free.

The tool has few moving parts and has an extremely high level of operational reliability. And because we both design and manufacture the TA14 Wire Cutter ourselves, we can guarantee both a complete stock of spare parts and rapid service when required. Changeable bit edges is made of high speed steel.

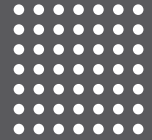
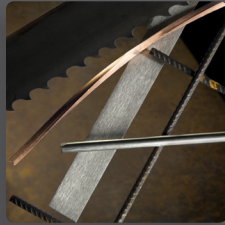

# WIRE CUTTER LINDOVA TA14

SEE OUR ENTIRE PRODUCT RANGE AT: [WWW.LINDOVA.SE](http://WWW.LINDOVA.SE)

Tool head

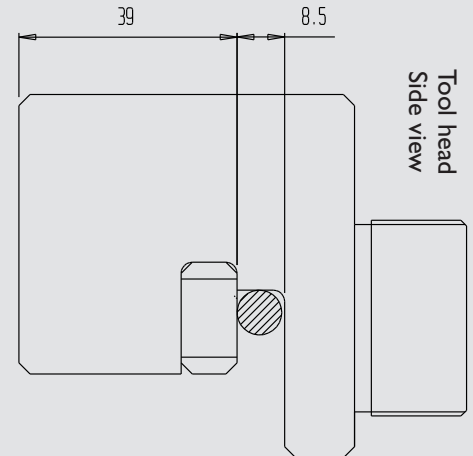
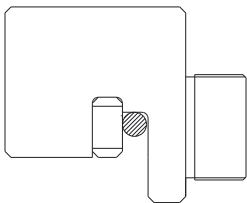

Tool head  
Side view

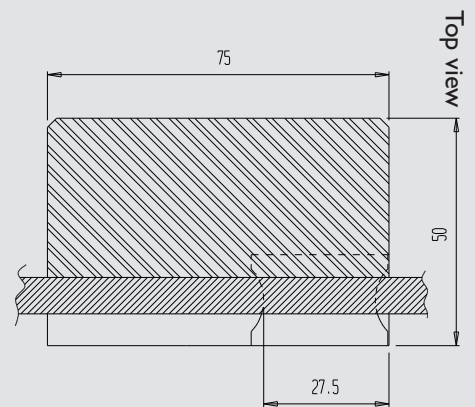

Top view

## Drive unit

Designation	Weight	Cutting pressure*	Length	Ø Cylinder	Max dim.
TA14S-530	2.4 kg	24 kN	446 mm	68 mm	Ø 8 mm
TA14S-730	4.0 kg	40 kN	446 mm	86 mm	Ø 8 mm

Vibration level: < 2.5 m/s<sup>2</sup>

Noise level: 63 dB (A)



\* At 6 bar (90 Psi) pressure